

IEEE Standard for Bar Coding for Distribution Transformers

Sponsor
**Transformers Committee
of the
IEEE Power Engineering Society**

Approved 20 June 1996
IEEE Standards Board

Abstract: Bar code label requirements for overhead, pad-mounted, and underground-type distribution transformers are set forth in this standard. Included herein are requirements for data content, symbology, label layout, print quality, and label life expectancy.

Keywords: bar coding, distribution transformers

The Institute of Electrical and Electronics Engineers, Inc.
345 East 47th Street, New York, NY 10017-2394, USA

Copyright © 1996 by the Institute of Electrical and Electronics Engineers, Inc.

All rights reserved. Published 1996. Printed in the United States of America.

ISBN 1-55937-835-2

No part of this publication may be reproduced in any form, in an electronic retrieval system or otherwise, without the prior written permission of the publisher.

Introduction

(This introduction is not part of IEEE Std C57.12.35-1996, IEEE Standard for Bar Coding for Distribution Transformers.)

This standard describes requirements for bar code labels on distribution transformers when specified by users. The intent of the bar code label described in this standard is to provide basic identification information for a transformer, as an aid in linking to more detailed information about the transformer that may reside in a utility company's central database. This standard describes requirements for a permanent bar code label that may be part of the nameplate, as well as temporary bar code label, intended primarily for material management purposes.

Requirements described in this standard address bar code label format, desired location of labels on specific type transformers, and performance requirements of the bar code labels. To the extent possible, industry standard bar code specifications and test methods are described. Use of this standard will promote standardization and uniformity in the use of bar code labels on distribution transformers.

The Accredited Standards Committee on Transformers, Regulators, and Reactors, C57, that reviewed and approved this document, had the following membership at the time of approval:

P. E. Orehek, Chair
vacant, Vice Chair
John A. Gauthier, Secretary

Electric Light and Power Group	E. A. Bertolini T. Diamantis K. Hanus M. C. Mingoia (<i>Alt.</i>) P. Orehek G. Paiva J. Sullivan
Institute of Electrical and Electronics Engineers	W. B. Binder J. D. Borst J. H. Harlow J. W. Matthews L. Savio H. D. Smith (<i>Alt.</i>) G. H. Vaillancourt
National Electrical Manufacturers Association	G. D. Coulter P. Dewever (<i>Alt.</i>) J. Douglas S. Endersbe A. Ghafourian P. Hopkinson K. R. Linsley R. L. Plaster (<i>Alt.</i>) H. Robin
Tennessee Valley Authority	F. Lewis
Underwriters Laboratories, Inc	M. Schacker
US Department of Agriculture, REA	J. Bohlk
US Department of Energy, Western Area Power Administration	Kenneth C. Wolohon
US Department of Interior, Bureau of Reclamation	R. Chadwick
US Department of the Navy, Civil Engineering Corps	H. P. Stickley

At the time it approved this standard, the IEEE/PES Transformers Committee had the following officers:

J. H. Harlow, Chair
W. B. Binder, Vice Chair
J. W. Matthews, Secretary
Georges Vaillancourt, Standards Coordinator

At the time this standard was completed, the Working Group on Distribution Transformer Bar Code Labels had the following membership:

Ron Jordan, Co-Chair
Ed Smith, Co-Chair

Anibal Alcintara, Jr.	Rick Hollingsworth	Thomas Pekarek
Glenn Anderson	John Hunt	Jack Phipps
Jim Antweiler	Kelley Knoerr	David Rolling
Jerry Bishop	John Lazar	John Rossetti
Alex Chan	Timothy Lewis	Jerry Rowe
Tom Diamantis	Jim Long	Robert Scheu
Kevin Edwards	Dave Lyon	Jerry Smith
Dudley Galloway	Al Maguire	Ronald J. Stahara
Ali Ghafourian	Angelynn McCain	Lou Tauber
John Gilbertson	Matthew C. Mingoia	Al Traut
Ken Hanus	Norvin Mohesky	Dorman Whitley
Cass Hermerla	Gerry Paiva	Alan L. Wilks
J. Quinton Hodge	Clyde Pearson	

Other individuals who have contributed review and comment are the following:

Claude Hertz	Dan Mullen	Norm Weiland
Bert Moore	LaVerne Stetson	

The following persons were on the balloting committee:

Edward J. Adolphson	D. J. Cash	Dudley L. Galloway
D. J. Allan	D. Chu	A. A. Ghafourian
Raymond Allustiarti	Thomas F. Clark	Donald A. Gillies
Michael S. Altman	J. L. Corkran	R. S. Girgis
Glenn Andersen	Dan W. Crofts	R. D. Graham
J. C. Arnold	John C. Crouse	Robert L. Grubb
J. Arteaga	V. Dahinden	R. L. Grunert
J. Aubin	John N. Davis	F. J. Gryszkiewicz
Donald E. Ayers	R. C. Degeneff	Michael E. Haas
Roy A. Bancroft	T. Diamantis	Geoff H. Hall
Ron L. Barker	Larry E. Dix	E. Hanique
David A. Barnard	R. F. Dudley	N. Wayne Hansen
E. A. Bertolini	John A. Ebert	Kenneth S. Hanus
Wallace B. Binder	K. Edwards	James H. Harlow
J. H. Bishop	Fred E. Elliott	Frank W. Heinrichs
W. E. Boettger	D. J. Fallon	William R. Henning
J. V. Bonucchi	P. T. Feghali	K. R. Highton
John D. Borst	Jeffrey A. Fleeman	Peter J. Hoefler
C. V. Brown	Michael A. Franchek	Philip J. Hopkinson
M. Cambre	Jerry M. Frank	J. W. Howard

Edgar Howells	Michael I. Mitelman	J. R. Rossetti
J. Hunt	Harold R. Moore	G. W. Rowe
Y. Peter Iijima	W. E. Morehart	Mahesh P. Sampat
C. W. Johnson	D. H. Mulkey	Leo J. Savio
Anthony J. Jonnatti	C. R. Murray	William E. Saxon
R. D. Jordan	R. J. Musil	Robert W. Scheu
E. Kallaur	William H. Mutschler	Devki N. Sharma
J. J. Kelly	Carl G. Niemann	V. Shenoy
William N. Kennedy	E. T. Norton	Hyeong J. Sim
James P. Kinney	Paul E. Orehek	Stephen D. Smith
Sheldon P. Kennedy	Gerald A. Paiva	James E. Smith
Alexander D. Kline	Klaus Papp	J. Ed Smith
J. G. Lackey	Bipin K. Patel	J. W. Smith
Michael Y. Lau	Wesley F. Patterson, Jr.	Ronald J. Stahara
J. P. Lazar	J. M. Patton	W. W. Stein
Frank A. Lewis	Paulette A. Payne	Ron W. Stoner
Harold F. Light	Larry C. Pearson	John C. Sullivan
S. R. Lindgren	Thomas J. Pekarek	David Sundin
Larry A. Lowdermilk	Dan D. Perco	Louis A. Tauber
Richard I. Lowe	Mark D. Perkins	James B. Templeton
Donald L. Lowe	V. Q. Pham	V. Thenappan
Joseph Ma	Linden W. Pierce	James A. Thompson
William A. Maguire	R. L. Plaster	R. W. Thompson
K. T. Massouda	Donald W. Platts	Thomas P. Traub
John W. Matthews	Bertrand Poulin	E. R. Trummer
A. D. McCain	Jeewan L. Puri	Georges H. Vaillancourt
Jack W. McGill	Vadim Raff	Robert A. Veitch
Charles J. McMillen	J. D. Ramboz	Loren B. Wagenaar
W. J. McNutt	Charles T. Raymond	Barry H. Ward
Charles P. McShane	Pierre Riffon	R. J. Whearty
Ross McTaggart	Peter G. Risse	D. W. Whitley
Sam P. Mehta	S. M. A. Rizvi	A. L. Wilks
C. Kent Miller	Chris A. Robbins	Charles W. Williams
Matthew C. Mingoia	R. B. Robertson	
Russell E. Minkwitz	A. L. Robinson	

When the IEEE Standards Board approved this standard on 20 June 1996, it had the following membership:

Donald C. Loughry, *Chair*
Richard J. Holleman, *Vice Chair*
Andrew G. Salem, *Secretary*

Gilles A. Baril	E. G. "Al" Kiener	Arthur K. Reilly
Clyde R. Camp	Joseph L. Koepfinger *	Ronald H. Reimer
Joseph A. Cannatelli	Stephen R. Lambert	Gary S. Robinson
Stephen L. Diamond	Lawrence V. McCall	Ingo Rüsck
Harold E. Epstein	L. Bruce McClung	John S. Ryan
Donald C. Fleckenstein	Marco W. Migliaro	Chee Kiow Tan
Jay Forster *	Mary Lou Padgett	Leonard L. Tripp
Donald N. Heirman	John W. Pope	Howard L. Wolfman
Ben C. Johnson	Jose R. Ramos	

* Member Emeritus

Also included are the following nonvoting IEEE Standards Board liaisons:

Satish K. Aggarwal

Alan H. Cookson

Chester C. Taylor

Rochelle L. Stern
IEEE Standards Project Editor

CLAUSE	PAGE
1. Overview	1
1.1 Scope	1
1.2 Purpose	1
2. References	1
3. Definitions	2
4. Bar code label requirements	3
4.1 Permanent bar code label	3
4.2 Temporary bar code label	5
Annex A (Informative) Manufacturer/repair facility identification codes	12

IEEE Standard for Bar Coding for Distribution Transformers

1. Overview

1.1 Scope

This standard sets forth bar code label requirements for overhead, padmounted, and underground-type distribution transformers. Included herein are requirements for data content, symbology, label layout, print quality, and label life expectancy.

This standard assumes the existence of central transformer databases within utility companies so that bar code labels need only carry basic transformer identification data.

1.2 Purpose

The purpose of this standard is to promote standardization and uniform use of bar code labels on distribution transformers when specified by the user. Longer term, it is hoped that the bar codes provided as a result of this standard will serve as an integral part of electrical utility material and information management systems.

2. References

When the following standards are superseded by an approved revision, the revision shall apply:

AIM Uniform Symbology Specification USS-39-1986.¹

ANSI X3.182-1990. Bar Code Print Quality—Guidelines.²

ANSI C57.12.20-1994 (R1995), Requirements for Overhead-Type Distribution Transformers, 500 kVA and Smaller: High Voltage, 34 500 Volts and Below; Low Voltage, 7970/13 800 Y Volts and Below.

¹AIM publications are available from the Automatic Identification Manufacturers at (412) 963-8588.

²ANSI publications are available from the Sales Department, American National Standards Institute, 11 West 42nd Street, 13th Floor, New York, NY 10036, USA.

ANSI C57.12.21-1995, Requirements for Pad-Mounted, Compartmental-Type, Self-Cooled, Single-Phase Distribution Transformers with High-Voltage, 34 500 GrdY/19 920 Volts and Below; Low-Voltage, 240/120 Volts; 167 kVA and Smaller.

ANSI C57.12.22-1989, Requirements for Pad-Mounted, Compartmental-Type, Self-Cooled, Three-Phase Distribution Transformers with High-Voltage Bushings, 2500 kVA and Smaller, High-Voltage, 34 500 GrdY/19 920 Volts and Below; Low Voltage, 480 Volts and Below.

ANSI C57.12.23-1992, Standard for Transformers—Underground-Type, Self-Cooled, Single-Phase Distribution Transformers with Separable Insulated High-Voltage Connectors—High-Voltage, 24 940 GrdY/14 400 V and Below; Low-Voltage, 240/120 V; 167 kVA and Smaller.

ANSI C57.12.24-1994, Requirements for Underground-Type Three-Phase Distribution Transformers, 2500 kVA and Smaller: High-Voltage, 34 500 GrdY/19 920 Volts and Below; Low-Voltage, 480 Volts and Below.

ANSI C57.12.25-1990, Requirements for Pad-Mounted, Compartmental-Type, Self-Cooled, Single-Phase Distribution Transformers with Separable Insulated High-Voltage Connectors: High-Voltage, 34 500 GrdY/19 920 Volts and Below; Low-Voltage, 240/120 Volts; 167 kVA and Smaller.

ANSI C57.12.26-1993, Standard for Transformers-Pad Mounted, Compartmental-Type, Self-Cooled, Three-Phase Distribution Transformers for Use with Separable Insulated High-Voltage Connectors, High-Voltage, 34 500 GrdY/19 920 Volts and Below; 2500 kVA and Smaller.

ANSI C57.12.40-1990, Requirements for Secondary Network Transformers, Subway and Vault Types.

ASTM B117-95, Standard Method of Salt Spray (Fog) Apparatus.³

ASTM G53-95, Standard Recommended Practice for Operating Light- and Water-Exposure Apparatus for Exposure of Nonmetallic Materials.

IEEE Std C57.12.00-1993, IEEE Standard General Requirements for Liquid-Immersed Distribution, Power, and Regulating Transformers (ANSI).⁴

3. Definitions

3.1 ASCII: The code described in ANSI X3.4-1986, using a coded character set consisting of 7-bit coded characters (8 bits, including parity check), used for information interchange among data processing systems, communications systems, and associated equipment. The ASCII set consists of control characters and graphic characters.

3.2 bar: The darker element of a bar code.

3.3 bar code: An array of rectangular marks and spaces in a predetermined pattern.

3.4 bar code symbol: An array of rectangular bars and spaces that are arranged in a predetermined pattern following specific rules to represent elements of data that are referred to as characters. A bar code symbol typically contains a leading quiet zone, start character, data character(s) including a check character (if any), stop character, and a trailing quiet zone.

3.5 bidirectional bar code symbol: A bar code symbol format that permits decoding of the contents whether scanned in one direction or the reverse direction.

³ASTM publications are available from the American Society for Testing and Materials, 100 Barr Harbor Drive, West Conshohocken, PA 19428-2959, USA.

⁴IEEE publications are available from the Institute of Electrical and Electronics Engineers, 445 Hoes Lane, P.O. Box 1331, Piscataway, NJ 08855-1331, USA.

3.6 character: A letter, digit, or other special form that is used as part of the organization, control, or representation of data. A character is often in the form of a spatial arrangement of adjacent or connected strokes.

3.7 character set: Those characters that are available for encoding within the bar code symbol.

3.8 check character: A calculated character often included within a bar code symbol whose value is used for performing a mathematical check of the validity of the decoded data.

3.9 code density: The number of characters that can appear per unit of length.

3.10 discrete bar code symbology: A bar code symbology where the spaces between characters (intercharacter gap) are not part of the encoding scheme.

3.11 interpretation line: A human-readable interpretation of the bar code that is clearly identifiable with the bar code symbol that shall represent the encoded characters.

3.12 intercharacter gap: The space between the last bar of one character and the first bar of the next character, which separates the two adjacent characters. *Syn.:* intercharacter space.

3.13 quiet zone: The area immediately preceding the start character and following the stop character, which contains no markings.

3.14 space: The lighter element of a bar code, usually formed by the background between the darker elements of the bar code.

3.15 start and stop characters: Distinct bar/space patterns used at the beginning and end of each bar code symbol that provide initial timing references and direction-of-read information to the coding logic.

3.16 3-of-9 bar code: A variable length, bidirectional, discrete, self-checking, alphanumeric bar code. Its basic data character set contains the following 43 characters: 0 to 9, A to Z, -, ., /, +, \$, %, and space. Each character is composed of 9 elements—5 bars and 4 spaces. Three of the nine elements are wide (binary value 1) and six are narrow (binary value 0). A common character (*) is used exclusively for both a start and stop character.

4. Bar code label requirements

Overhead, padmount, and subsurface type distribution transformers may be labelled with permanent and/or temporary bar code labels, as specified by the user.

4.1 Permanent bar code label

4.1.1 Purpose of the permanent bar code label

The information contained on the permanent bar code label is to be used as the access key to a database after initial receipt of the transformer.

4.1.2 Data content and data format

4.1.2.1 Required data content

The permanent bar code label shall contain the following data elements:

- a) Manufacturer identification code
- b) Transformer serial number

These data elements shall consist of combinations of one or more of the following 43 characters:

0 to 9, A to Z, -, ., /, +, \$, %, and space.

4.1.2.1.1 Manufacturer/repair facility identification code

The transformer manufacturer shall be identified with a unique two-digit character string. See annex A for specific manufacturer codes currently in use at the time of publication.

4.1.2.1.2 Transformer serial number

The transformer serial number shall be an alphanumeric character string, assigned by the manufacturer, not exceeding 13 alphanumeric characters in length.

4.1.2.2 Data format

The information encoded on the permanent bar code label will appear in the following format:

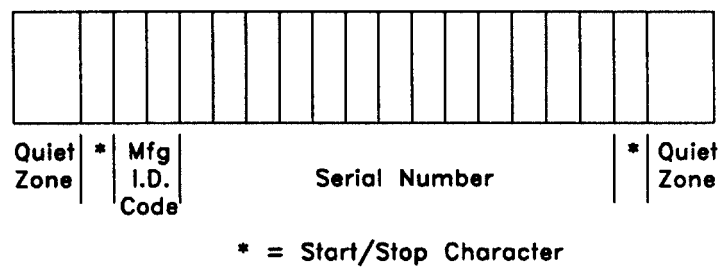

Figure 1—Data format, permanent label

4.1.3 Bar code symbology for the permanent label

The bar code symbology utilized on the permanent label shall be Code 39, also referred to as Code 3-of-9, in accordance with the Automated Identification Manufacturers' Uniform Symbol Specification for Code 39.⁵

4.1.4 Permanent label printing requirements

4.1.4.1 Bar code symbol print density

The bar code symbol shall be of medium density (4 to 7 characters per inch [cpi]) with a narrow bar width of 0.010 in (0.025 cm) to 0.015 in (0.038 cm), and a wide-to-narrow ratio of 3:1. The intercharacter gap shall be equal in width to the width of a narrow element.

4.1.4.2 Quiet zones

Quiet zones no less than 0.25 in (0.64 cm) in length shall immediately precede and follow the bar code symbol.

4.1.4.3 Dimensions

The height of the bar code symbol shall be no less than 0.24 in (0.61 cm).

4.1.4.4 Interpretation line

A human readable interpretation of the data included in the bar code shall be printed immediately beneath the bar code symbol. The height of the interpretation line shall be no less than 0.10 in (0.25 cm).

⁵Information on references can be found in clause 2

4.1.5 Permanent bar code label placement on transformer

The preferred location for the permanent bar code label, including both the bar code symbol and its accompanying interpretation line, is on the transformer nameplate. As an alternative, the bar code label may be placed on a separate nameplate adjacent to the transformer nameplate.

4.1.6 Permanent label quality/durability requirements

Permanent bar code label symbols are intended to be readable with commonly available scanning equipment for the required lifetime of the transformer nameplate as defined by IEEE Std C57.12.00-1993.

The readability of the nameplate bar code label may, however, be affected by the specific scanner equipment being used and by environmental conditions in which the scanning operation is being performed. Users may wish to address these considerations in their specifications. The following durability tests described in 4.1.6.1 through 4.6.1.3 shall be performed.

4.1.6.1 Salt spray test

A bar code permanent nameplate shall be tested for 1500 h in a 5% salt spray in accordance with ASTM B117-94 E1. Following the test, the bar code label shall retain print quality as described in 4.1.6.3.

4.1.6.2 Ultraviolet accelerated weathering test

A bar code permanent nameplate label shall be exposed for 500 h in accordance with ASTM G53-95, utilizing the FS-40 bulb with a cycle of 4 h ultraviolet at 55 °C followed by 4 h condensation at 40 °C. Following the test, the bar code label shall retain print quality as described in 4.1.6.3.

4.1.6.3 Print quality retention

After completion of tests described in 4.1.6.1 and 4.1.6.2, the bar code label will have met the requirements of this standard if it can be successfully scanned. Successful scanning is achieved when a bar code is read (correctly interpreted) on four of five attempts using a wand-type or laser-type scanner. The scanner shall be used in accordance with operating procedures specified by the scanner manufacturer.

4.2 Temporary bar code label

4.2.1 Purpose of temporary bar code label

Temporary bar code labels are to be used to facilitate initial receipt and installation processing of transformers.

4.2.2 Data content and data format

4.2.2.1 Required data content

The temporary bar code label shall contain the following data elements:

- a) Manufacturer identification code
- b) Transformer serial number
- c) User defined identification number

These data elements shall consist of combinations of one or more of the following 43 characters:

0 to 9, A to Z, -, ., /, +, \$, %, and space

4.2.2.1.1 Manufacturer/repair facility identification code

The transformer manufacturer shall be identified with a unique two-digit character string. See annex A for specific manufacturer codes currently in use at the time of publication.

4.2.2.1.2 Transformer serial number

The transformer serial number shall be an alphanumeric character string, assigned by the manufacturer, not exceeding 13 alphanumeric characters in length.

4.2.2.1.3 User-defined identification number

User-defined identification numbers shall be alphanumeric character strings, assigned by the customer, not exceeding 13 alphanumeric characters in length.

4.2.2.2 Data format

The information encoded on the temporary bar code label will appear in the following format:

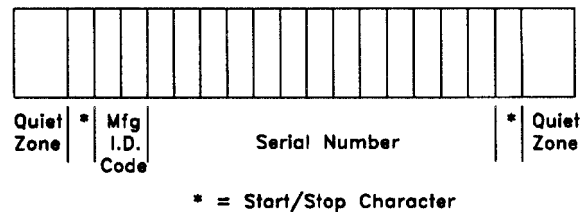
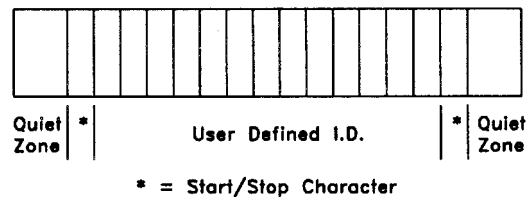

Figure 2—Data format, temporary label

4.2.3 Bar code symbology for temporary label

The bar code symbology utilized on the temporary label shall be Code 39, also referred to as Code 3-of-9, in accordance with the Automated Identification Manufacturers' Uniform Symbol Specification for Code 39.

4.2.4 Temporary bar code label location/layout/printing requirements

4.2.4.1 Temporary bar code label location

Temporary bar code labels will be attached to the transformer in the following locations described in 4.2.4.1.1 through 4.2.4.1.5.

4.2.4.1.1 Overhead-type distribution transformers single-phase 50 kVA and below

The temporary bar code shall be located on the cover, toward the periphery, in segment 1. See figure 3.

4.2.4.1.2 Overhead type distribution transformers single-phase 75 kVA and above and three-phase

The temporary bar code shall be located on the tank wall, at or above the height of the upper support lug, on the dividing line between segments 2 and 3, with a tolerance of ± 45 degrees. See figures 3 and 4.

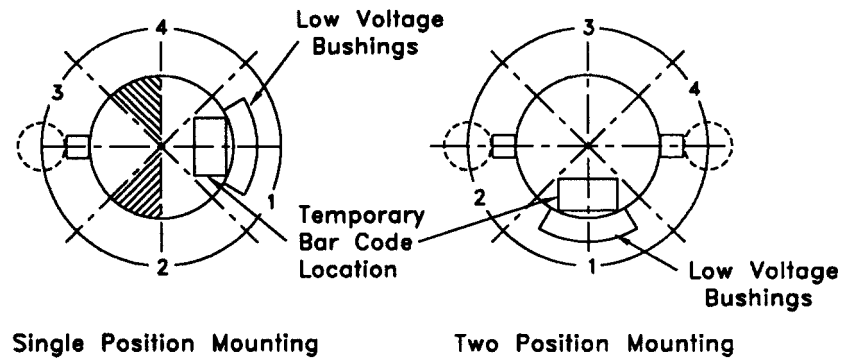

Figure 3—Temporary bar code location on overhead type distribution transformers single-phase, 50 kVA and below

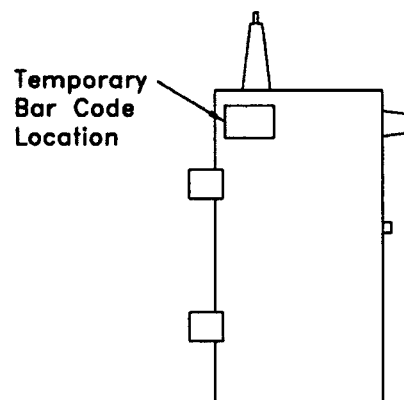

Figure 4—Temporary bar code location on overhead-type distribution transformers single-phase 75 kVA and above and three phase

4.2.4.1.3 Single-phase and three-phase padmounted transformers

The temporary bar code label shall be located on the back of the transformer in the upper right corner of a vertical surface of the tank. See figures 5 and 6.

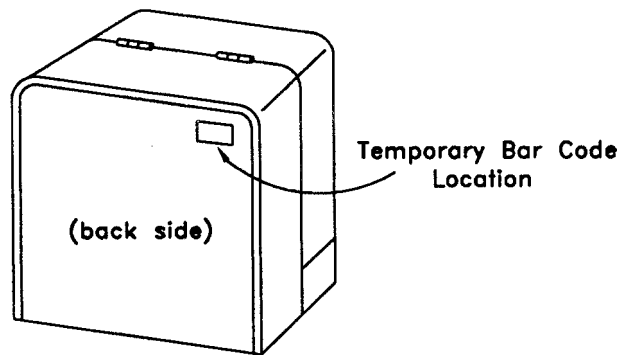

Figure 5—Temporary bar code location on single-phase padmounted transformers

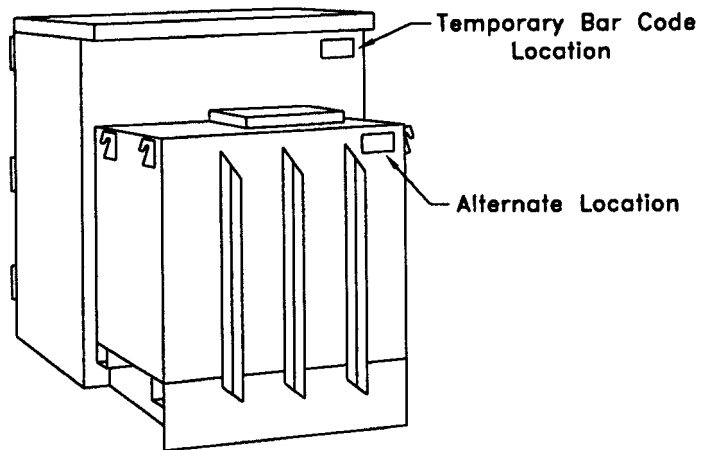
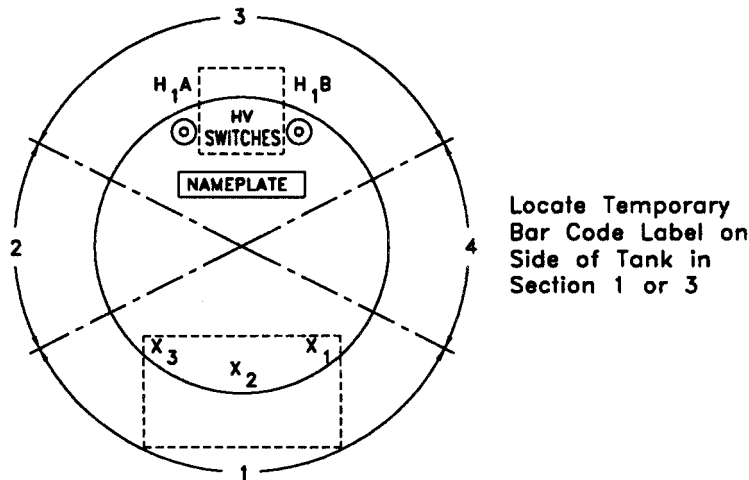

Figure 6—Temporary bar code label location on three-phase padmounted transformers

4.2.4.1.4 Temporary bar code label location on single-phase subsurface transformers

The temporary bar code label shall be located on the side of the transformer in Section 1 or Section 3. See figure 7.



Locate Temporary Bar Code Label on Side of Tank in Section 1 or 3

Figure 7—Temporary bar code label location on single-phase subsurface transformers

4.2.4.1.5 Temporary bar code label location on three-phase and network-type subsurface transformers

The temporary bar code label shall be located on the high-voltage end of the transformer near the permanent nameplate. See figure 8.

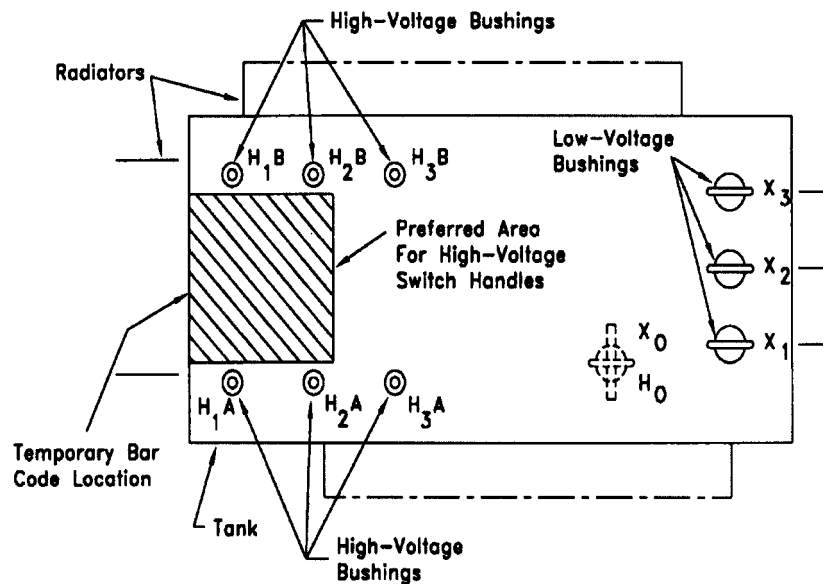

Figure 8—Temporary bar code label location on three-phase and network-type subsurface transformers

4.2.4.2 Temporary bar code label layout

The temporary bar code label shall not be greater than 3 in high (7.6 cm) × 5 in long (12.7 cm) in size.

The layout for the label shall be as follows:

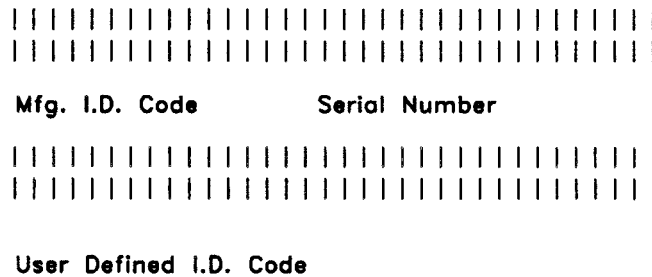

Figure 9—Label layout

4.2.4.3 Bar code symbol print density

The bar code symbol shall be of medium density (4 to 7 characters per inch [cpi]) with a narrow bar width of 0.010 in (0.025 cm) to 0.015 in (0.038 cm), and a wide-to-narrow ratio of 3:1. The intercharacter gap shall be equal to the width of a narrow element.

4.2.4.4 Quiet zones

Quiet zones no less than 0.25 in (0.64 cm) in length shall immediately precede and follow the bar code symbol.

4.2.4.5 Dimensions

The height of the bar code symbol shall be no less than 0.24 in (0.61 cm).

4.2.4.6 Interpretation line

A human readable interpretation of the data included in the bar code shall be printed immediately beneath the bar code symbol(s). The height of the interpretation line shall be no less than 0.10 in (0.25 cm).

4.2.5 Temporary bar code label durability requirements

It is intended that temporary bar code labels be scannable for a minimum of two years from time of transformer shipment. Materials for the labels and printed characters shall be selected to prevent fading, cracking, peeling, loss of adhesion, or any other condition that would render the label unreadable during the two year period. The readability of the bar code label may, however, be affected by the specific scanner equipment being used and by environmental conditions in which the scanning operation is being performed. Users may wish to address these considerations in their specifications.

As a test of label durability, the following performance tests described in 4.2.5.1 through 4.2.5.4 shall be conducted on newly printed sample labels.

4.2.5.1 Salt spray test

A temporary bar code label shall be affixed to a test panel. The test panel shall be of the same material and processing as used in production, and shall be cleaned, coated, and cured using the production coating system. The test panel with bar code label affixed shall be tested for 1000 h in a 5% salt spray in accordance with ASTM B117-95. Following the test, the bar code label shall retain print quality as described in 4.2.5.4.

4.2.5.2 Ultraviolet accelerated weathering test

A test panel with test bar code label attached shall be prepared as described in 4.2.1. The test panel and label shall be exposed for 500 h in accordance with ASTM G53-95, utilizing the FS-40 bulb with a cycle of 4 h ultraviolet at 55 °C followed by 4 h condensation at 40 °C. Following the test, the bar code label shall retain print quality as described in 4.2.5.4.

4.2.5.3 General performance

When tested as specified in 4.2.5.1 and 4.2.5.2, the bar code labels shall show no evidence of smearing or erosion of the bar-coded symbol, delamination, loss of adhesion, discoloration, wrinkling, cracking, or any effect that is detrimental to the bar-coded symbol or the adhesion of the test labels to the test panel.

4.2.5.4 Print quality retention

After completion of tests described in 4.2.5.1 and 4.2.5.2, the print quality of each label shall be measured in accordance with ANSI X3.182-1990. The minimum print quality grade shall be C (1.5) using a measuring aperture of 0.010 in (0.025 cm) as recommended in the ANSI X3.182-1990 guideline.

Annex A Manufacturer/repair facility identification codes

(Informative)

The manufacturer/repair facility identification codes suggested below represent, in part, codes that are currently utilized for bar coding distribution transformers; and represent, in part, an arbitrary preference for the first two characters of the manufacturer's or repair facility's name. The listing below may not represent a comprehensive list of distribution transformer manufacturers or repair facilities.

The following manufacturer/repair facility identification codes shall be utilized:

Manufacturer/repair facility	Code
ABB	AB
Arkansas Electric Cooperatives, Inc.	AE
Atlantic Power	AP
Balteau Standards	BS
California Sierra Transformer	CS
CamTran	CT
Canadian Electrical Services	CE
Carte	CA
Central Moloney	CM
Cooper	CP
Delta Star	DS
Delta Y	DY
Dowzer	DO
Ermco	ER
Fayetteville Transformer	FT
Federal Pacific	FP
Federal Pioneer	SC
Ferranti Packard	RR
General Electric	GE
General Electric-Prolec	GP
Hevi-Duty	HD
Howard Industries	HI
Kuhlman	KU

Manufacturer/repair facility	Code
Line Power Manufacturing	LP
Magnetek Transformer	ME
Magnetic Electric	MC
MGM Transformer	MG
Mid Central Electric	MI
Moloney Electric	MO
Neco Hammond	NH
Nelson Electric	NC
Niagara Transformer	NT
Nix Electric	NE
Partner Technologies	PT
Pauwels	PA
Powell Esco	PE
Prolec	PR
R. E. Uptegraff Manufacturing	UP
San Angelo Electric	SE
Southern Transformers	ST
Southwest Electric	SW
Square D	SD
T & R Electric	TR
TransCanada Transformers	TT
Transformer Sales & Services	TS
United Utility Supply/KAEC	US
Van Tran	VI
Virginia Transformer	VT
Ward Transformer	WT
Westinghouse	WE